

High pressure hose reels with electric drive

1/2", 100 meters

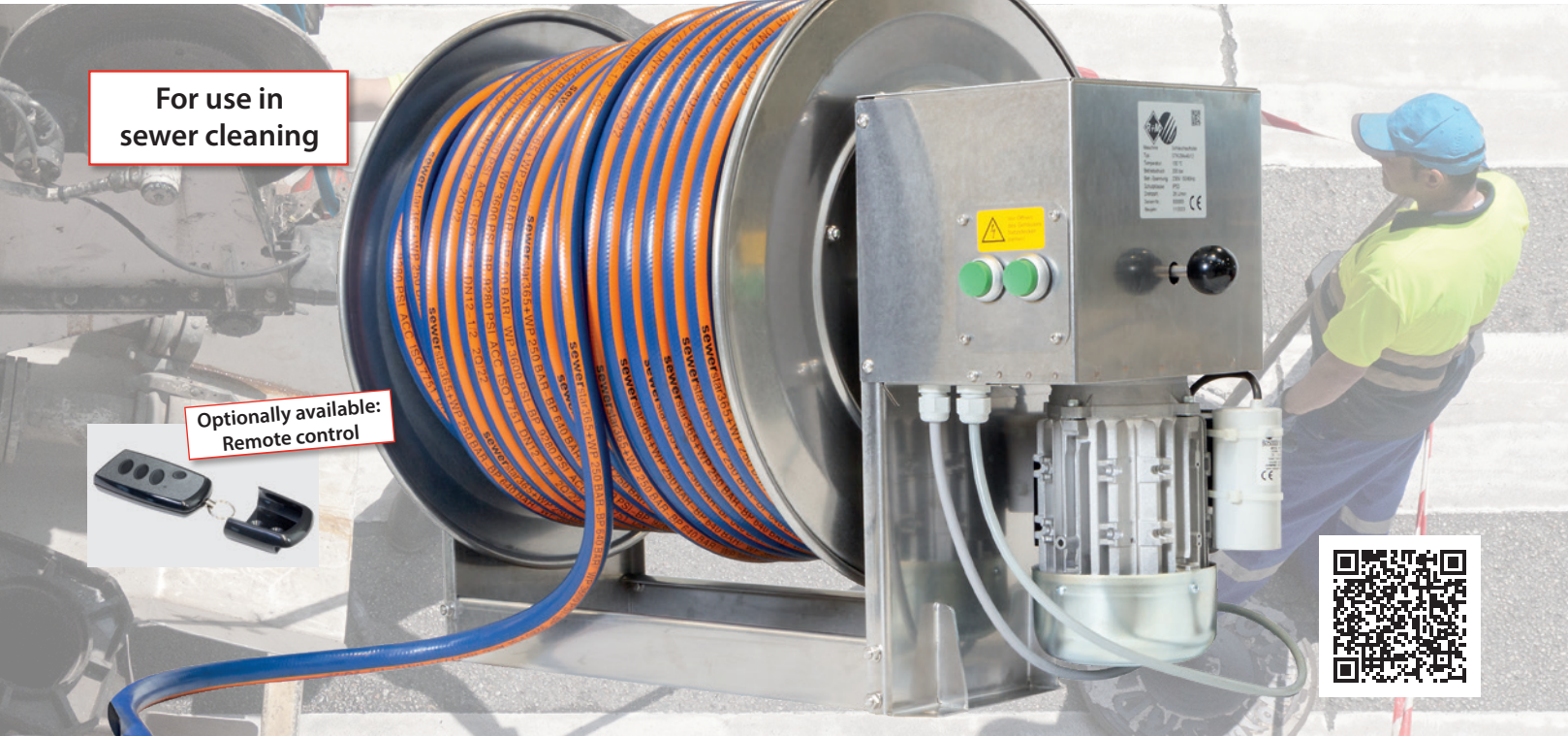

The choice of perfection



For use in sewer cleaning

Optionally available: Remote control



STKI hose reel for sewer cleaning

- The base frame is made out of canted steel sheet profiles which stand for excellent stability.
- For horizontal winding above ground.
- Die Trommel hat eine annähernd geschlossene Stahlblechnabe und läuft in wartungsfreien Kunststoff-Lagerbuchsen.
- Easy to use thanks to electric drive and remote control (optionally available).
- Drum can be separated from the drive thanks to the sliding clutch.
- Right/left rotation can be controlled via buttons.
- Suitable for the mediums water or water with cleaning detergent.
- The hose reels are all equipped with a swivel ST-322. The swivels ST-322 are completely made out of stainless steel and have a slide ring as sealing element.

Take advantage of our numerous products that work together to achieve the best cleaning results

Our selection of robust sewer cleaning nozzles from R+M / Suttner: All nozzles are made from high-quality materials and offer you the right variant for all problems.



ST-358.2 Sewer Jetting Turbo:
They are perfect for drilling through clogs with the forward-facing, rotating nozzle. 5-8 powerful rear-facing nozzles power the sewer cleaning nozzle.



Extremely high impact force:
The long cone nozzle for long ranges.

ST-3500 Industrial high-pressure gun with long cone nozzle: For large volume flows up to 350 bar at 150 °C. Ideal for shaft cleaning, but also for off-shore cleaning applications or in shipping.

High pressure hose reels with electric drive

1/2", 100 meters



The choice of perfection

STKI with electric drive

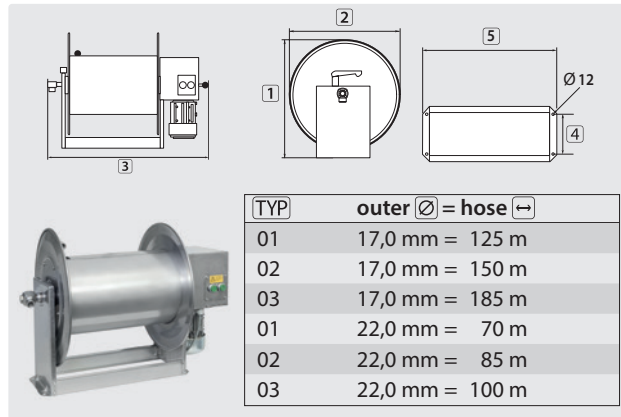

Radio remote control retrofit kit.
868.3 MHz hand transmitter, receiver and rod antenna

R+M Nr.
739 704 013

Stainless steel V2A / AISI 304. With 230 V / 24 V / 12 V, 50 Hz worm gear motor, 0.22 kW with manual claw clutch

R+M Nr.	G & S	V	DN	P	°C	⊗	1	2	3	4	5	TYP
739 602 30	1/2" F	230 V / AC	12	100-300 bar	90 °C	24 kg	515 mm	460 mm	730 mm	153 mm	480 mm	01
739 602 302	1/2" F	230 V / AC	12	100-300 bar	90 °C	25 kg	515 mm	460 mm	830 mm	153 mm	580 mm	02
739 602 303	1/2" F	230 V / AC	12	100-300 bar	90 °C	26 kg	515 mm	460 mm	930 mm	153 mm	680 mm	03
739 600 240	1/2" F	24 V / DC	12	100-300 bar	90 °C	24 kg	515 mm	460 mm	730 mm	153 mm	480 mm	01
739 600 241	1/2" F	24 V / DC	12	100-300 bar	90 °C	25 kg	515 mm	460 mm	830 mm	153 mm	580 mm	02
739 600 242	1/2" F	24 V / DC	12	100-300 bar	90 °C	26 kg	515 mm	460 mm	930 mm	153 mm	680 mm	03
739 600 120	1/2" F	12 V / DC	12	100-300 bar	90 °C	24 kg	515 mm	460 mm	730 mm	153 mm	480 mm	01
739 600 121	1/2" F	12 V / DC	12	100-300 bar	90 °C	25 kg	515 mm	460 mm	830 mm	153 mm	580 mm	02
739 602 122	1/2" F	12 V / DC	12	100-300 bar	90 °C	26 kg	515 mm	460 mm	930 mm	153 mm	680 mm	03

ST-49 Ball Type Nozzles, 30°

Made out of wear-resistant, hardened stainless steel provided with front jet insert or blind plug (interchangeable). Angle of jet is 30°, sturdy wall thickness, long service life and a minimum of wear and tear.
Max. 500 bar

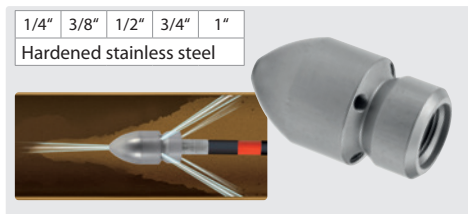

1/2" F.
Outside \varnothing 30 mm.
⊗ rear jets, with front jet



R+M Nr.	D	⊗
649 030 416 060	060	6
649 030 416 080	080	6
649 030 416 100	100	6
649 030 416 120	120	6
649 030 416 150	150	6
649 030 416 200	200	6
649 030 416 315	315	6

Milling Type Nozzles ST-49

Hardened stainless steel. With its 3 to 4 very strong concentrated forward jets and the sharp cutting edges the milling type nozzles will tear through almost any kind of blockage. The sharp edges cut, break and penetrate through every kind of blockage. Max. 300 bar

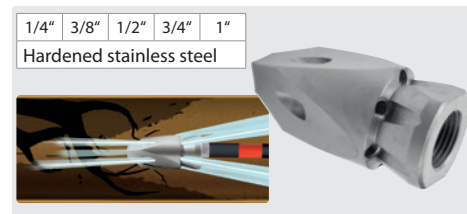

1/2" F. ⊗ 68 mm, \varnothing = 31 mm, ⊗ 0.17 kg. For tubes > 60 mm.
Lateral front jets with hardened stainless steel nozzle inserts.

R+M Nr.	D	Front	⊗
649 010 446 100	100	4	6
649 010 446 120	120	4	6
649 010 446 150	150	4	6
649 010 446 200	200	4	6
649 010 446 250	250	4	6
649 010 446 270	270	4	6
649 010 446 310	310	4	6
649 010 446 495	495	4	6
649 010 446 580	580	4	6

ST-49.2 Rotating Nozzles

Stainless steel. Brazen rotating body. Excellent cleaning by rotating nozzle jets. Exchangeable inserts included.
Excellent pulling power by min. 4 rear jets specially placed.
Pressure max. 350 bar.

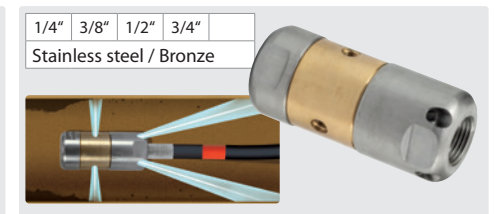

1/2" F. ⊗ rear jets. 3 side jets.
Outside \varnothing 38 mm.
⊗ 585 g.

R+M Nr.	D	⊗	⊗
649 050 435 100	100	5	84 mm
649 050 435 120	120	5	84 mm
649 050 435 150	150	5	84 mm
649 050 435 200	200	5	84 mm
649 050 435 250	250	5	84 mm
649 050 435 300	300	5	84 mm

Our ball-type sewer nozzles, milling-type nozzles ST-49.1 and ST-49.2 rotary nozzles are equipped with hardened stainless steel nozzle inserts. This significantly increases the efficiency compared to directly drilled nozzles. The service life is increased several times.

High pressure hose reels with electric drive

1/2", 100 meters

ST-358.2 Rotating nozzles

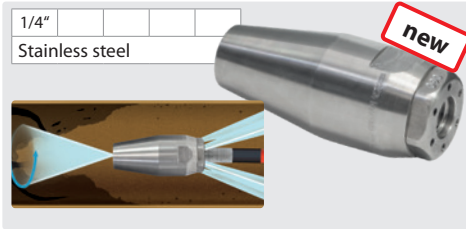

Rotor nozzles with integrated Rotor nozzle drivers are perfect for drilling through blockages with its rotary forward facing jet.

Driven up to the blockage by 5-8 powerful rear facing stainless steel nozzles the high speed forward facing spinning jet creates a cone shape that has enough cutting force to blast through roots and scale.

It is also ideal for cutting up and shredding tissue and fat deposits

Max. 275 bar/150 °C

R+M Nr.	D	C	thrust jets
200 358 650	050	1/4" F	5 x 0,4 mm
200 358 660	060	1/4" F	6 x 0,4 mm
200 358 670	070	1/4" F	7 x 0,4 mm
200 358 680	080	1/4" F	8 x 0,4 mm

ST-3500 Industrial high-flow gun

Industrial high-flow gun ST-3500, lance 500 mm with side handle.

Long Cast Nozzle.

Max. 350 bar / 200 l/min / 150 °C



Application:

- » Man hole cleaning
- » Paper Industry. Removal of snow balls during fibre jetting
- » Cleaning Tasks in Off-Shore or Marine Applications





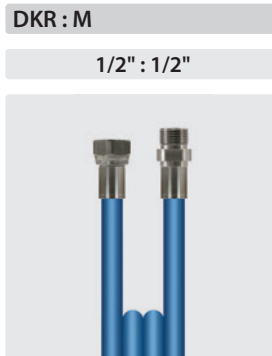

R+M Nr.	D	C
203 500 560	750 mm	1/2" F swivel

sewerstar365+ rubber-sewer cleaning hose

- » highly abrasion-resistant with an extremely long operating life
- » high flexibility by especially developed rubber compound
- » extremely abrasion-resistant, ageing resistant and weather-resistant surface
- » easy handling by low weight
- » excellent pressure resistance and tensile strength
- » very low bending radius
- » wire braid for high stability
- » interior and surface are made out of NBR/SBR
- » -40 °C - +150 °C, -40 °F - +302 °F



DN	P	⊙	⊘	BP	↔
10	280 bar	9.8 mm	16.9 mm	740 bar	40 m
					60 m
					80 m
					100 m
					120 m
12	250 bar	12.7 mm	22.6 mm	640 bar	40 m
					60 m
					80 m
					100 m
					120 m

R+M Nr.
432 557 100 040
432 557 100 060
432 557 100 080
432 557 100 100 
432 557 100 120 
432 557 120 040
432 557 120 060
432 557 120 080 
432 557 120 100 
432 557 120 120 