

PARTS BULLETIN

AMETEK
LAMB ELECTRIC DIVISION

MODEL NO.
116515-13

ISSUED: January 1994
REVISED: July 2001

5.7"/145mm DIAMETER, 24V, 3-STAGE, BY-PASS, BALL/BALL, TANGENTIAL DISCHARGE, AIR SEAL AND EPOXY

PARTS LIST

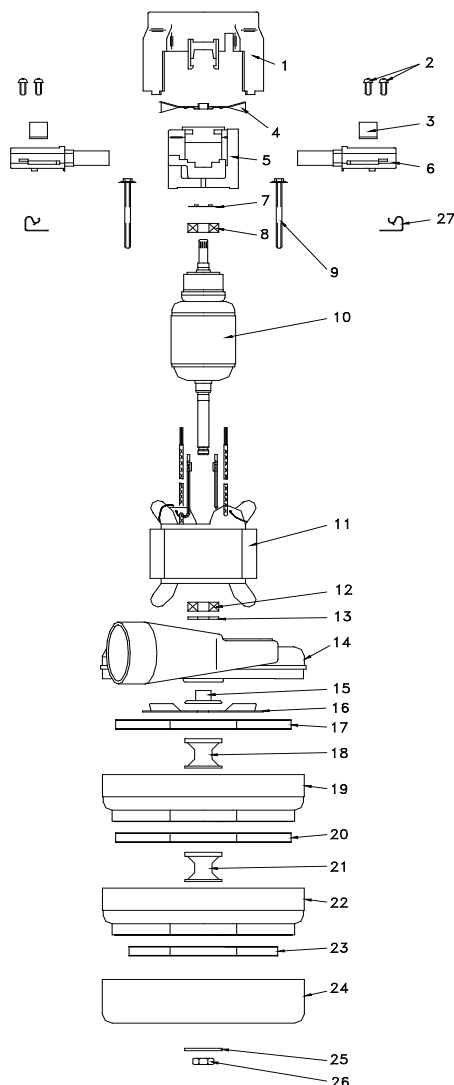

	<u>DESCRIPTION</u>	<u>REQUIRED</u>	<u>PART NO.</u>
1	HOUSING	1	60-3776-4
2	SCREW	4	50-7971
3	CLAMP	2	10-5477
4	FAN	1	0-3930-1
5	COMM END BRACKET	1	20-6581
6	BRUSH MECHANISM	2	33392-4
7	LOAD SPRING	1	10-3543
8	BALL BEARING	1	70-7613-2
9	SCREW	2	60-7952-6
10	ARMATURE	1	216514-00
11	FIELD	1	316514-00
12	BALL BEARING	1	70-7619-2
13	NEOPRENE WASHER	1	10-2481
14	FAN END BRACKET	1	45957
15	SPACER	1	30-2942
16	FAN	1	0-3939-1
17	ROTATING FAN	1	31120-4
18	SPACER	1	30-2943
19	STATIONARY FAN	1	31278-1
20	ROTATING FAN	1	31120
21	SPACER	1	10-2977-1
22	STATIONARY FAN	1	31373
23	ROTATING FAN	1	31275
24	FAN SHELL	1	30-3744-14
25	WASHER	1	40-2207
26	NUT	1	7491
27	CLIP	2	20-5110

PART SUBJECT TO CHANGE WITHOUT NOTICE.

*THIS INFORMATION IS FOR PART IDENTITY ONLY,
IT IS NOT TO BE USED AS DISASSEMBLY OR
ASSEMBLY INSTRUCTIONS.*

*REPLACEMENT OF ARMATURE OR FIELD REQUIRES
THE REPLACEMENT OF BRUSH MECHANISM.*