

User manual for hose reels Series ST and SOST

Applicable as from 01/05/2021

1. Intended use and application

- 1.1 Media to be used : Water, oil, air, grease, and food.
- 1.2 Fields of use : Industry, garages, trade, carriers, etc.
Food industry: Butcher shops, slaughterhouses, dairies, breweries, manufacturers of lemonade, mineral water, etc.

The material 1.4301 (V2A) used in the stainless steel reels is not suitable for chlorous environments (e.g. swimming pools).

- 1.3 Pressure range : 3/8" 0-400 bar; 1/2" 0-300 bar; 3/4" 0-200 bar
- 1.4 Temperature range : 0 – 90°C
- 1.5 Max. recoil force : 15 kp
- 1.6 Nominal Ø : 8 – 19 mm (3/8" – 3/4")

2. Weight

Series ST and SoST										
	ST14/10-12	SoST14	ST20/10-12	SoST-20	ST20/19	ST30/10-12	ST40/10/2	ST40/12/2	ST40/19/1	ST40/19/2
Weight [kg]	14	14	16	17,5	17	19	23	25	20	26,5

3. Hose mounting

- 3.1 Only use hoses that are suitable for the required pressure and temperature range.
- 3.2 Attach suitable fittings to the swivel (Fig. 1, Item 6) and pipe bend (Fig. 1, Item 4) (use suitable sealants). Attention! The swivel shall be connected using a flexible hose. If rigid piping is used, there is a risk of leakage at the swivel.
- 3.3 Remove the closing cap from the mounting opening (Fig. 1, Item 5). Fasten the hose reel to the provided sturdy base using 4 bolts (M8 or M10) or 2 screw clamps.
Bend the return spring as far as it will go by turning the drum in the direction of the arrow (spring on block) and then unbend it by one turn. Fix the drum with the locking screw (Fig. 2, Item 9) so that the pipe connection (Fig. 1, Item 4) is accessible in the mounting opening (Fig. 1, Item 5). The locking screw is included in the scope of supply.
Attention! When bending the return spring, it must be blocked and unbend after each turn. Uncontrolled return rotation of the drum may cause injuries to the operators as well as damage to the spring.
If the reel has already been provided with a hose, the locking screw has to be removed after installation of the reel (screw out completely, also refer to No. 3.6).
Roll out the hose in full length, guide one end of the hose (without bend restrictor) through the guide frame (Fig. 1, Item 1) and the drum opening and connect it to the connection pipe (Fig. 1, Item 4).
- 3.4 Loosen the locking screw (Fig. 2, Item 9) and allow the hose to retract while guiding the hose by hand. Attention! Remove the locking screw afterwards.

4. Adjustment of the hose guide frame

- 4.1 Upon delivery, the guide frame is in Position I (Fig. 1, 2, and 3) unless ordered otherwise.
- 4.2 For Position II (Fig. 2, 3, and 4) proceed as follows:
 - a. Release the guide frame (Fig. 1, Item 1).
 - b. Release the distance bar (Fig. 1, Item 3) and position it in the holes (Fig. 1, Item 2).

- c. Mount the guide frame in Position II according to Figures 2, 3, and 4.
- 4.3 For Position III (Fig. 2) proceed as follows:
- a. Release the guide frame (Fig. 1, Item 1) and mount it in Pos. III (Fig. 2).
 - b. Mount an additional distance bar (Fig. 1, Item 3) in the holes (Fig. 1, Item 2).

4.4 Hose brake:

The lower guide roll of the hose guide frame (Fig.1, Item 1) is mounted in elongated holes and can be moved. By adjusting the gap to the outer \varnothing of the hose, both rolls act as a hose brake.

An uncontrolled retraction of the hose can thus be avoided.

5. Installation of the hose reel

5.1 Installation and fields of use see below.

Use fixed installation (Fig. 1 and 2) only if the pulling direction of the hose will not be bent by more than 30° (Fig. 5).

Otherwise, use swivelling brackets acc. to Fig. 3.

When mounting the hose reel, an even load-bearing subsoil is required. The following subsoils are possible: Wood, steel, concrete, masonry, panel walls (a counterplate is required here).

The mounting holes must absolutely be in line with the hole pattern of the hose reel. When mounted in constrained position, there will be a distortion of the bearings. As a consequence, the drum will block. In order to avoid such mounting errors, we recommend to use the mounting consoles type KWH (Fig. 2 and 4, Item 11), type SKW (Fig. 3, Item 8), or type KHD (Fig. 1).

5.2 Hose reels and the chosen brackets shall always be mounted safely using 4 locking screws $\varnothing 8$ or $\varnothing 10$. When using dowels, pay attention to load-bearing masonry. (also refer to the WARNING!)

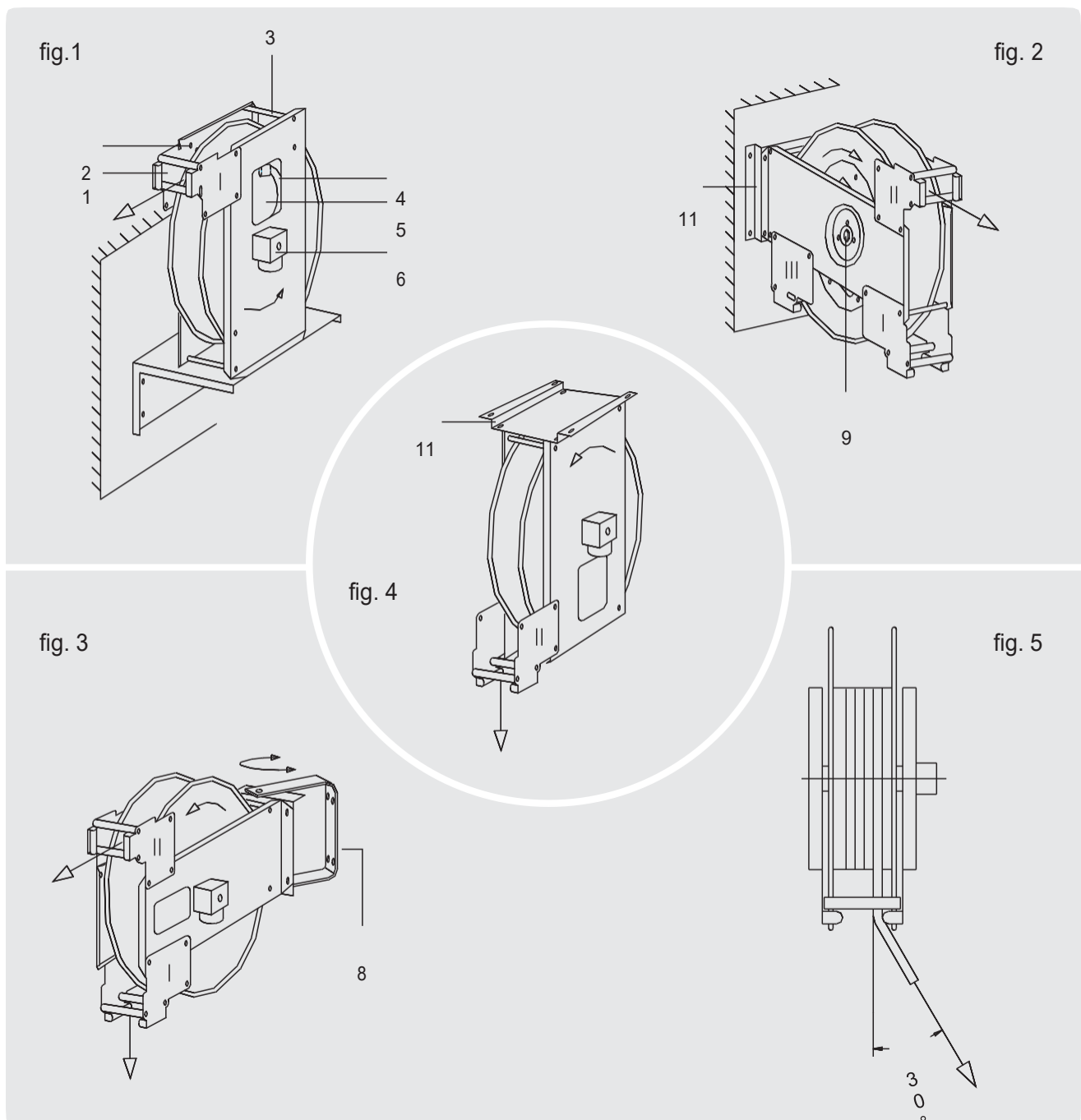

6. Guns

When using guns, a limitation of the flow (e.g. using diaphragms) can prevent recoil forces > 150 N. Also refer to "Richtlinien für Flüssigstrahler" (Guidelines for high-pressure cleaners)! Otherwise, the operators may be injured and the hose reel may be damaged.

7. Hose stopper

One hose stopper is included in the scope of supply. The enclosed inset kit enables use with hose diameters from 10 to 34 mm.

8. Repairs

Repairs in the area of the spring shall only to be effected by qualified personnel (also refer to the WARNING).

9. Maintenance

The hose reels are almost maintenance-free, only the two drum bearings shall be lubricated every six months using commercial machine oil.

The hose shall be checked for ruptures and cracks every month, especially at the junctions of the fittings. A high-pressure jet may cause injuries.

WARNING!

Possible hazards that may result from improper assembly, handling, or repair:

- Hose reels and swivelling brackets shall be fastened safely using 4 screws M8 or M10. Make sure of a load-bearing subsoil. Falling devices may cause severe accidents and even death under certain circumstances.
- Never allow any uncontrolled retraction of the hose. The swaying end of the hose or gun with lance may seriously injure any people that are close-by. To this end, set the hose brake according to No. 4.4.
After mounting the hose as well as any works on the locking device, always close the mounting window.
- Before carrying out any repairs, the hose has to be depressurised by switching off the pressure generator, closing the inlet valve, and opening the gun. Moreover, the spring has to be unbent completely. The spring shall be repaired by trained staff, only. Uncontrolled movement of the spring or non-compliance with the above-mentioned instructions may cause serious injuries.

Guarantee

The legal guarantee for our hose reels and spare parts is 1 year as from the date of delivery.

If the product is sold after a longer storage period at the customer's, the one-year guarantee shall only be extended if the final user returns the completed guarantee card to us.

The manufacturer's liability shall lapse if the user fails to comply with the mounting instructions and user manual and uses spare parts that are not covered by the guarantee.

In all other cases, our Terms and Conditions of Sale and Delivery shall apply.