

Installation instructions

Original language: German

Product group: Unloader ST-261

Product code: 200261500



The choice of perfection

Vers. May 20

www.rm-suttner.com

Technical data

| | |
|-------------------------------|------------------|
| Maximum permissible pressure | 250 bar / 25 MPa |
| Minimum pressure | 2 bar / 0,2 MPa |
| Maximum flow rate | 30.0 l/min |
| Water temperature permanently | max. 80°C |
| Ambient temperature | max. 60°C |
| Inlet connector | G3/8 f |
| Outlet connector | G3/8 f |
| Bypass | G1/4 f |
| Pressure gauge connector | G1/4 f |
| Pressure switch voltage | n.a |
| Pressure switch current | n.a |
| Cable | n.a. |
| Weight | 0.655 kg |
| Dimensions (W / H / D) | 85 x 140 x 40 |
| Max. solid material size | 50µm |

| Abbreviations and symbols | |
|---------------------------|---|
| f, m | Female thread; male thread |
| G | Whitworth pipe thread according to DIN ISO 228, ident. BSP= British Standard Pipe |

| | |
|--|--|
| | <p>The user must wear appropriate protective clothing, for example, in the form of gloves, shoes and goggles. The local safety regulations currently in force should always be observed.</p> |
| | <p>Please read these Installation Instructions carefully before using the equipment! Keep the Installation Instructions in a safe place for future use or for the next user! These Installation Instructions were prepared with great care. However, SUTTNER GmbH cannot be held responsible for any possible errors in the Installation Instructions or for any consequences arising thereof!</p> |

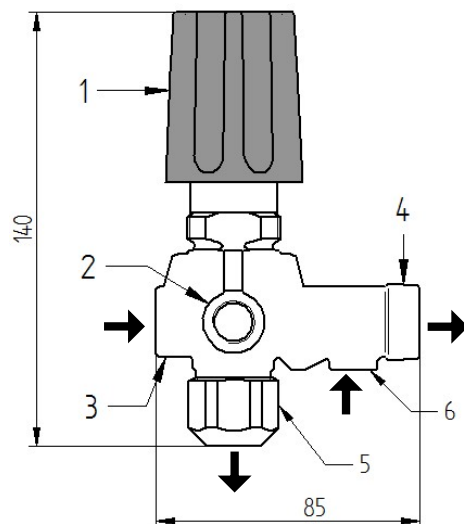

- 1 Setting dial
- 2 Pressure gauge connector
- 3 Inlet
- 4 Outlet
- 5 Bypass connector
- 6 Opt. chemical connector
- ➔ Flow direction

Description

Circulation valve

The circulation valve is used to feed the flow rate of a pump back to the pump inlet depending on the operating mode. This prevents the pump from being overloaded and the pressure on the HP hose and spray gun being too high.

The circulation valve operates according to the principle of a direct-acting, spring-loaded proportional seat valve. The circulation valve is infinitely adjustable. The valve housing is made of forged brass. All components which come into contact with the media are manufactured from anti-corrosion materials.

Depending on the volume used by the consumer and the pressure preset on the spring, the circulation valve opens a cross-section to the bypass in order to feed any excess volume back to the pump inlet. If no volume is dispensed from the consumer, bypass mode of the circulation valve is activated. In this case, the complete flow rate is fed back to the pump inlet.

Fittings and hoses must have an interior diameter (DN) of at least 10 mm. Depending on the design type, the circulation valve may not be operated with guns with a frost protection or weep function.

Intended use

The circulation valve is designed for use with water-operated high-pressure systems such as high-pressure washers.

All components of the HP system must be compatible with each other. The component with the lowest values (pressure, temperature, etc.) determines the maximal possible load of the HP system. The circulation valve does not replace the safety valve. Only operate the circulation valve together with a safety valve.

The circulation valve is approved only for use with Group II fluids as per EC 1272/2008. This can include, for instance, water and diluted commercially available cleaning or disinfection agents. All safety regulations and rules for high-pressure washers apply as well, e.g. DIN EN 60335-79-2 and DIN EN 1829-1.

Dispensing flammable, explosive, caustic or toxic substances is forbidden!

The circulation valve may not be used with abrasive substances.

To avoid damaging the circulation valve, install a fine filter with a recommended mesh size of 50 µm into the water inlet to the high-pressure pump.

Normative references

- The product is classed as a pressure-maintaining component within the terms of Pressure Equipment Directive 2014/68/EU. Due to the operating parameters, it comes under the scope of Article 4 / Paragraph 3 of this guideline ("good engineering practice") and therefore no Declaration of Conformity and CE marking are allowed!
- The product must not be installed in equipment complying with the Pressure Equipment Directive 2014/68/EU.
- The product is a standard part within the terms of Machinery Directive 2006/42/EC!

Symbols and their meanings



Hazard!

If these instructions are not followed there is a danger of physical injury, danger to life and material damage!



Please comply with the Operating Instructions!

Incorrect operation can lead to severe injury. Read the Operating Instructions before using the equipment.



Wear safety gloves!



Wear protective goggles!



Risk of injury due to high pressure!

Risk of injection or severe injury to persons. Keep clear of nozzle. Do not direct discharge stream at persons.



Description of imminent hazard and failure to avoid hazard will result death



Description of hazard and possible resulting injuries or death.



Description of hazard that could result in minor or moderate injury.

For your safety

This Suttner product is state of the art and complies with generally recognised health and safety regulations. Due to the high pressures and temperatures nonetheless there is the danger of material damage and injury for users and other persons. Please comply with these Installation Instructions at all times and the relevant regulations for liquid jet sprayers.

For details regarding personal protective equipment, refer to the German accident prevention regulations "Personal protective equipment" (VBG101, at present draft). Personal protective equipment includes for example overalls, head protection, easy-grip protective gloves and non-slip boots, metatarsal foot protection, respiratory protection, ear protection, eye or face protection.

- Cease operation immediately if any leakage or malfunctions occur.
- Malfunctions that may affect safety are to be rectified immediately.
- The circulation valve may only be used in a technically perfect condition, unmodified in any way, for the purpose intended, in awareness of and compliance with safety requirements and potential hazards and when following these Installation Instructions. Any other or additional use is deemed inappropriate.
- All assembly or installation work must be carried out by authorised specialist personnel.
- Also comply with the operating instructions for equipment and accessories connected to the circulation valve and with the applicable regulations for cleaning agents.



Risk of burning or scalding due to hot media!

If the high-pressure system has been used with hot water, allow the equipment to cool down to below 45°C due to the risk of scalding or burning before starting assembly and maintenance work!



Wear protective gloves!

Assembly

Delivery scope

The circulation valve is not preset when supplied. The pressure gauge connector must be closed.



Usage notes

Circulation valves are high-quality fittings, which must be handled with particular care. The sealing surfaces on the seat and piston are machined to achieve the necessary tightness. The penetration of foreign bodies into the valve must be avoided during assembly, installation and during operation. The function of a circulation valve can be impaired by hemp, Teflon tape or other sealant as well as by welding beads. Even rough treatment of the finished circulation valve during storage, transport and assembly may cause a circulation valve to leak. If the circulation valves are painted, care must be taken that the sliding parts do not come into contact with paint.

The ST-261 circulation valve may be installed vertically and horizontally. In order to ensure proper functioning of the circulation valves, they must be installed in such a way that no impermissible static, dynamic or thermal stresses may act on the circulation valve. During assembly, ensure the maximum tightening torque is not exceeded.

- Switch the high-pressure generator (1) off before carrying out assembly work on the high-pressure system.
- Secure the high-pressure generator against being unintentionally switched on.

- Turn the water supply off.
- Ensure that system sections and lines to be opened are not under pressure.
- Seal the screw connectors in accordance with your intended use with an appropriate sealant such as Teflon sealing tape or a liquid sealant (see R+M Catalogue, Chapter 06, Adhesives and sealing materials).
- Tighten the screw connections in the HP area to 20 Nm
- Install the circulation valve into the pressure line whilst observing the direction of through-flow
- Create a return line (6)
- Ensure the equipment meets the requirements of the machine guideline after installing the circulation valve in a machine/system!



**Make sure that the flow resistance in the return line (6) is not too high.
To do so, make sure to use an adequately large line.**

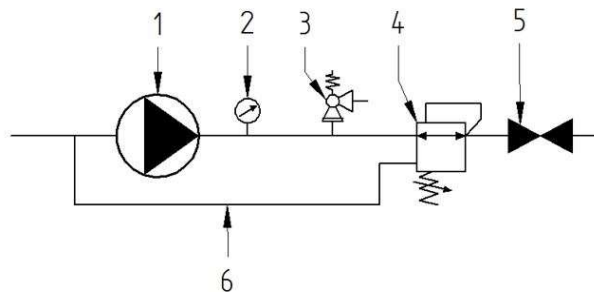

- 1 High-pressure generator
- 2 Pressure gauge
- 3 Safety valve
- 4 Circulation valve
- 5 Spray gun
- 6 Return line

Modification

No modifications of any kind are to be made to the circulation valve!

Setting



The manufacturer of the high-pressure system is responsible for the correct setting and awareness of safety requirements and potential hazards during installation!

- First, set the safety valve (3) to the operating pressure, before setting the circulation valve
- Unscrew the setting dial fully anticlockwise
- Switch on the high-pressure generator (1)
- Open the spray gun (5)
- Screw the setting dial on clockwise until the desired operating pressure is reached or until there is no pressure increase on the pressure gauge.
- To make a fine adjustment, turn the setting dial slowly back again with the spray gun (5) open until the operating pressure falls a few bar below the desired value. Do not apply pressure to the setting dial. Turn the setting dial a quarter turn clockwise with the spray gun (5) open. The optimum operating pressure is now set
- Actuate the spray gun (5) several times and check the operating pressure on the pressure gauge (2)
- Ideally, select a nozzle size in the lance so that when working at the desired operating pressure, no water flows through the return line.

Setting of pressure limiting

- remove setting dial (2)
- loosen the screw (6 hex 2,5)
- fix the nut(5 SW27) and screw setting sleeve (4 SW12) down to the stop 7.
- The minimum pressure can be setted with nut (3 SW10).

Now setting is complete. Reassemble parts in reverse order.



If set incorrectly, this can cause permanent overflowing of the flow rate into the return line. This reduces the service life of the circulation valve.

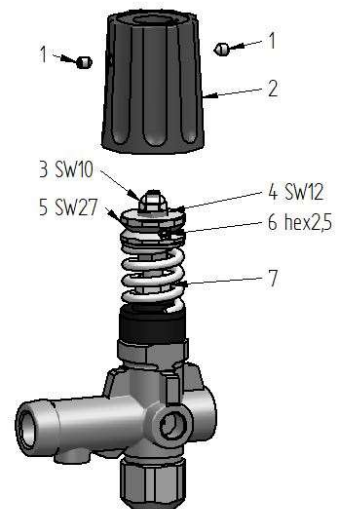

Maintenance



Assembly, maintenance and repair work may only be carried out by persons trained in maintenance and repair work on high-pressure systems. Use only spare parts approved by Suttner GmbH. Only use high-pressure components (hoses, connectors, etc.) approved for the respective pressure and temperature range.

- Perform an annual exterior visual inspection to make sure the circulation valve is safe to use.
- Does the circulation valve leak?
- Does the circulation valve show signs of mechanical damage?
- Does the setting dial turn?
- Does the circulation valve toggle correctly?

After max. 1000 operating hours or a year or if hot water (exceeding 80°C) and chemicals are used after 500 operating hours or 6 months: Check valve parts (O-rings, support rings, hose clips) for damage and if necessary replace completely with a Suttner repair kit.

After max. 3000 operating hours or 3 years or if hot water (exceeding 90°C) and chemicals are used after 1500 operating hours or 18 months: Replace valve parts (O-rings, support rings, hose clips) completely with a Suttner repair kit.

After each use with sticky or impure fluids, rinse the circulation valve with clear water.

Disposal



Please dispose of old equipment in an environmentally friendly manner.

Old equipment contains valuable recyclable materials which should be salvaged for recycling. Please therefore dispose of old equipment at suitable collection points.

Manufacturer

Suttner GmbH
Hauptstraße 15-17
33818 Leopoldshöhe
Germany

info@rm-suttner.com
www.rm-suttner.com