

General

These fully stainless steel ST-167 / ST-168 injectors provide the option of enabling two larger cross-sections in order to guarantee virtually no pressure drop in flush mode. This makes it possible when using large volumes of water to leave the injector permanently on the high pressure line without adversely affecting cleaning performance in cleaning and flush modes. A selector enables switching between injector and flush mode, whereby two holes duct the water parallel to the injector (bypass operation) and injector operation, where the volume of water available is ducted through the injection area.

With the ST-167 chemicals can be drawn in when used in combination with a foam lance such as for example the ST-72, ST-74 or ST-75 or a surge regulator or multi-regulator nozzle and be sprayed or foamed using the nozzle selected.

With the ST-168 no active, i.e. separate, air intake foam lance is necessary to generate the foam. The volume of air needed for foaming is fed via an additional connector on the injector. Use of a large cross-section spraygun such as for example the ST-2720, ST-2725, ST-3100 or ST-3300 with suitable lances and foam hoses such as the "blufood" is recommended. The ST-168 is particularly suitable for use at low or medium pressure from 5 bar upward of water intake pressure and generates excellent foam given the appropriate compressed air supply.

The injector operates with a maximum inlet pressure of 350 bar and due to the use of high-quality materials can be used at temperatures up to 100 °C. Throughput direction is indicated with arrows to ensure ease of installation.



General safety notes

- To guarantee safe operation the bypass injector may only be used in accordance with these Operating Instructions.
- Keep these Operating Instructions in a safe place for later reference.
- Please also observe the safety instructions for the detergent and if applicable of the high pressure cleaner manufacturer.
- Do not mix detergents one with the other.
- Wear suitable protective clothing and gloves when working.
- Never direct the high-pressure jet at persons or other living creatures.
- Read the safety data sheets and observe the corresponding safety and handling regulations.



Intended use

- The bypass injector ST-167/168 is designed for admixture of detergents to water and for straightforward rinsing with water.
- Only Pressure Equipment Directive (PED) Group 2 liquids may be used as media. In case of doubt contact the equipment manufacturer.
- The unit may only be used with a suitable pressure generator.
- The unit is not designed for use with persons (children included) with restricted sensory and mental capabilities due to lack of experience and/or lack of knowledge unless they are supervised by a person responsible for their safety or if they have received instruction from that person in use of the equipment.
- In general children are forbidden to use this equipment.



Info

In addition the required safety and legal regulations for the respective type of use must be observed. This also applies to all accessories used.



Connection lines used and the ST-167/168 injector unit itself must be flushed clear for 20 seconds prior to any change of detergent. In the case of very powerful detergents please contact the manufacturer who can then assess whether operation with this unit is possible. Any form of operation of the ST-167/168 injector unit over and above is deemed impermissible.



Qualified personnel

The bypass injector may only be installed by qualified personnel able to operate the bypass injector properly. Qualified personnel are persons familiar with installation, commissioning and decommissioning, operation, maintenance and repair and who hold a qualification appropriate to their work.

Troubleshooting

ST-167

Injector does not suck in foaming agent or detergent from the container or no foam is generated:

- Dosage nozzle blocked - clear nozzle with thin wire as necessary. If strongly scaled select new dosage nozzle.
- Selector lever in wrong position
- No dosage nozzle in foaming agent intake hose
- Intake hose damaged
- Intake hose not immersed in foaming agent
- Wrong lance: ST-167 needs a foam lance with air injector

ST-168

Injector does not suck in foaming agent or detergent from the container or no foam is generated:

- Dosage nozzle blocked - clear nozzle with thin wire as necessary. If strongly scaled select new dosage nozzle.
- Selector lever in wrong position
- No dosage nozzle in foaming agent intake hose
- Intake hose damaged
- Intake hose not immersed in foaming agent
- Wrong spraygun: ST-168 needs a foam gun with large cross-sections.
- Air connection not correct or not connected in the first place
- Compressed air line shut-off valve closed
- Recommended is connection of a pressure reducer in the compressed air line (2 – 6 bar)

Mode of operation

The selector lever switches between two modes of operation: injector mode and rinse mode.

For „injector“ mode turn the selector lever to the „injector“ position. Note: always turn the lever to the end stop in order to ensure correct operation. In the injector mode the detergent/foaming agent intake and dosage is via the injector. Dosage is via dosage nozzles or alternatively via the ST-161 dosage

valve. Depending on use the chemical/water mixture can be sprayed or foamed via a suitable lance. For foaming with the ST-167 a foam lance with an air injector (ST-72, ST-74 and ST-75) is used or alternatively with the ST-168 air can be fed via the additional compressed air connector provided in order to foam the detergent.

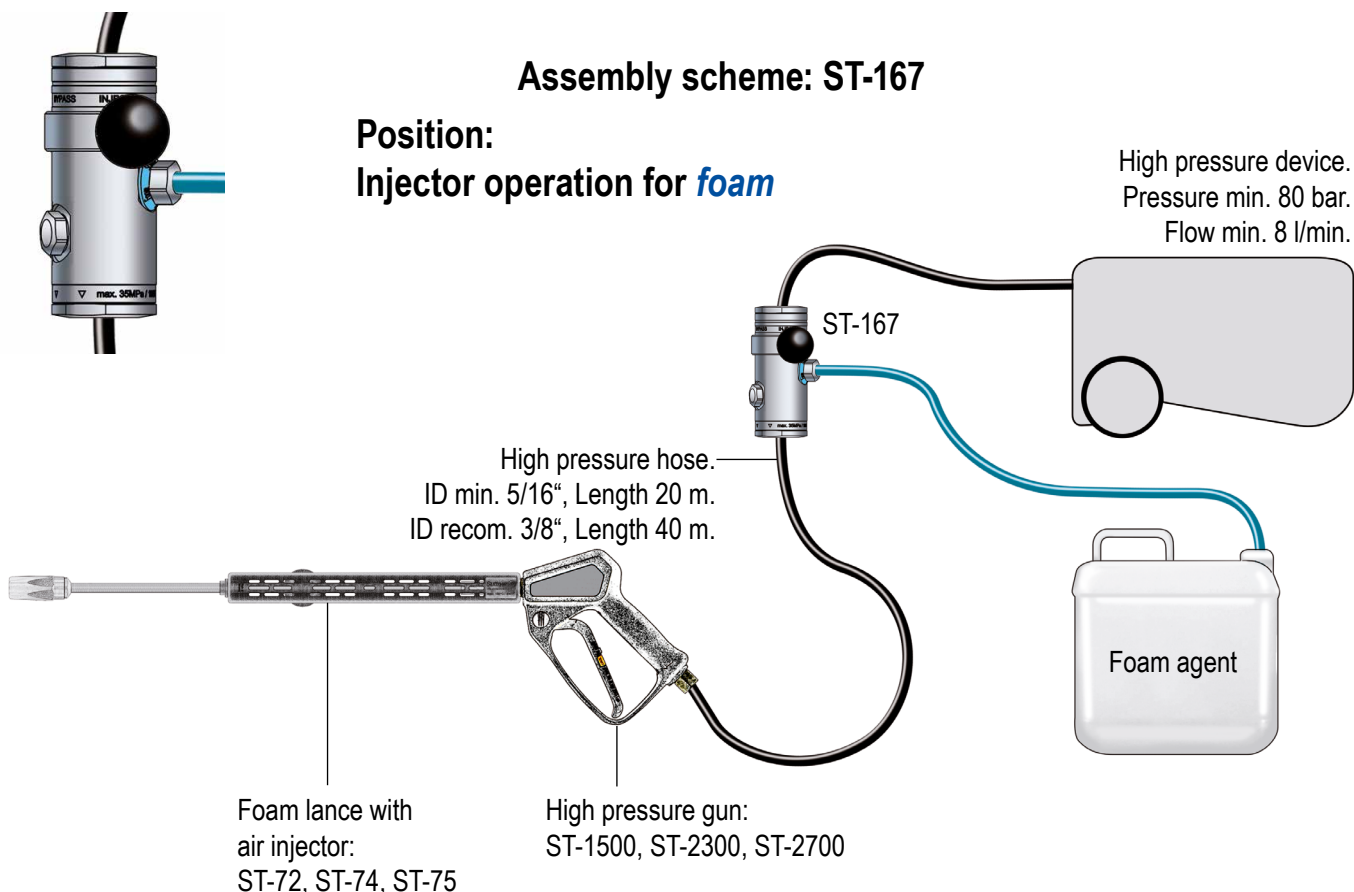



Position: Assembly scheme: ST-167
Injector operation for *cleaning agent*

High pressure device.
 Pressure min. 80 bar.
 Flow min. 8 l/min.

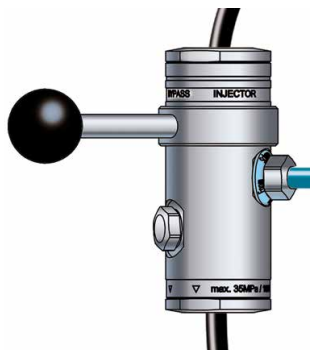
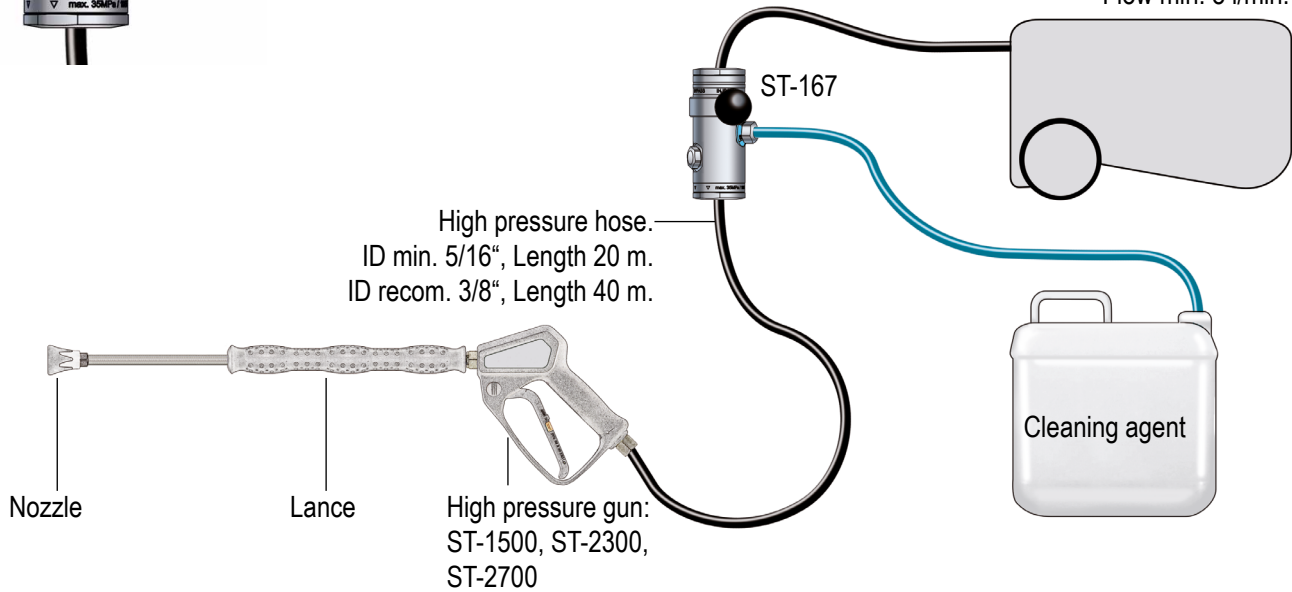

Position: Assembly scheme: ST-167
Injector operation for *washing operation*

High pressure device.
 Pressure min. 80 bar.
 Flow min. 8 l/min.

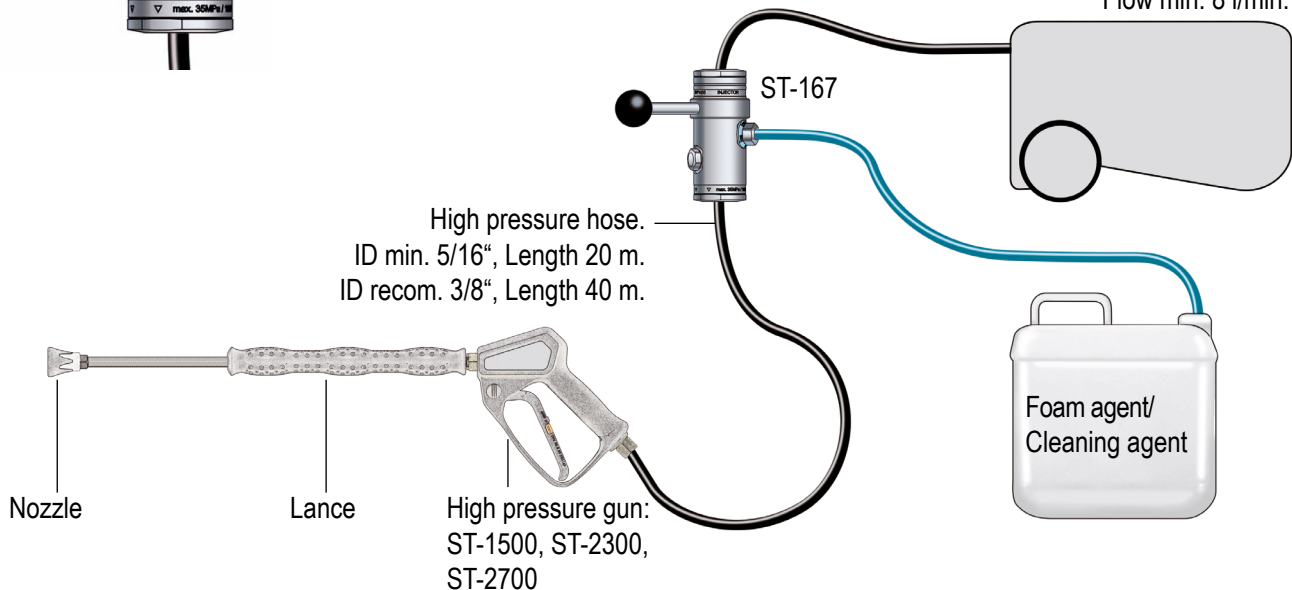

Assembly scheme: ST-168



Position:
Injector operation for *foam*

High or low pressure device.
 Pressure min. 5,6 bar.
 Pressure max. 350 bar.
 Flow 4 l/min.

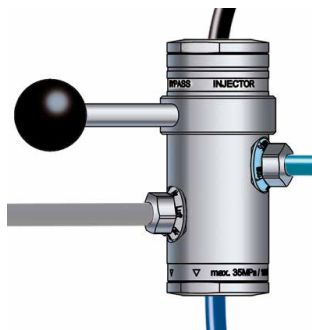
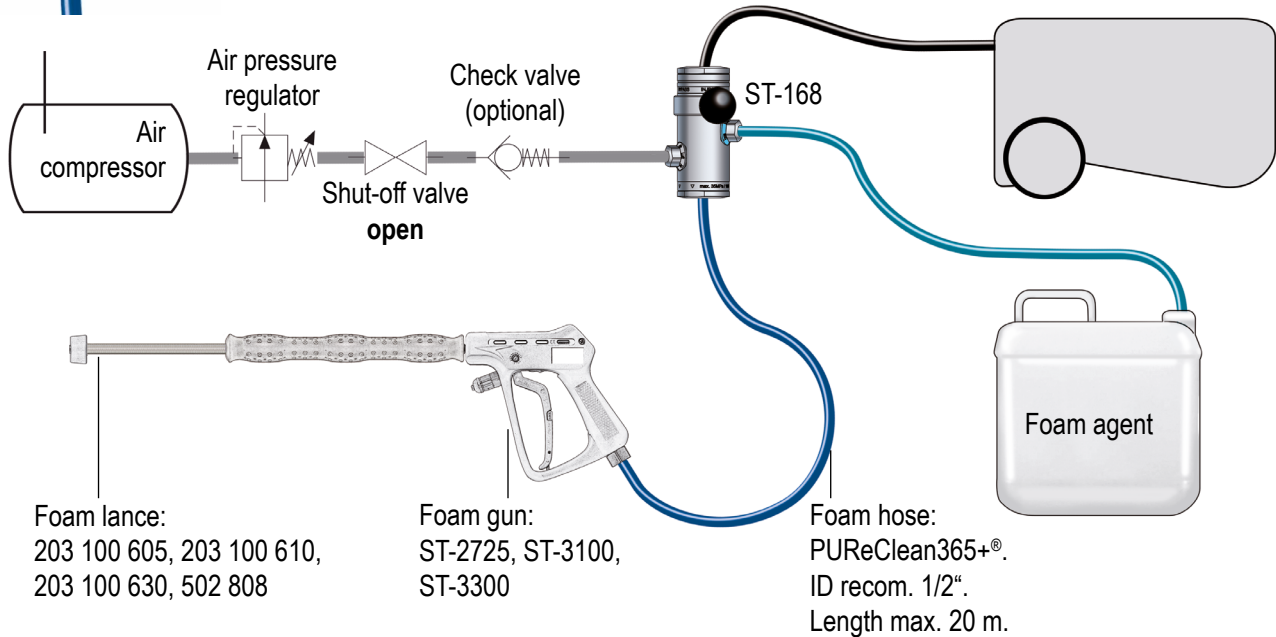

Position:
Injector operation for *washing operation*

High or low pressure device.
 Pressure min. 5,6 bar.
 Pressure max. 350 bar.
 Flow 4 l/min.

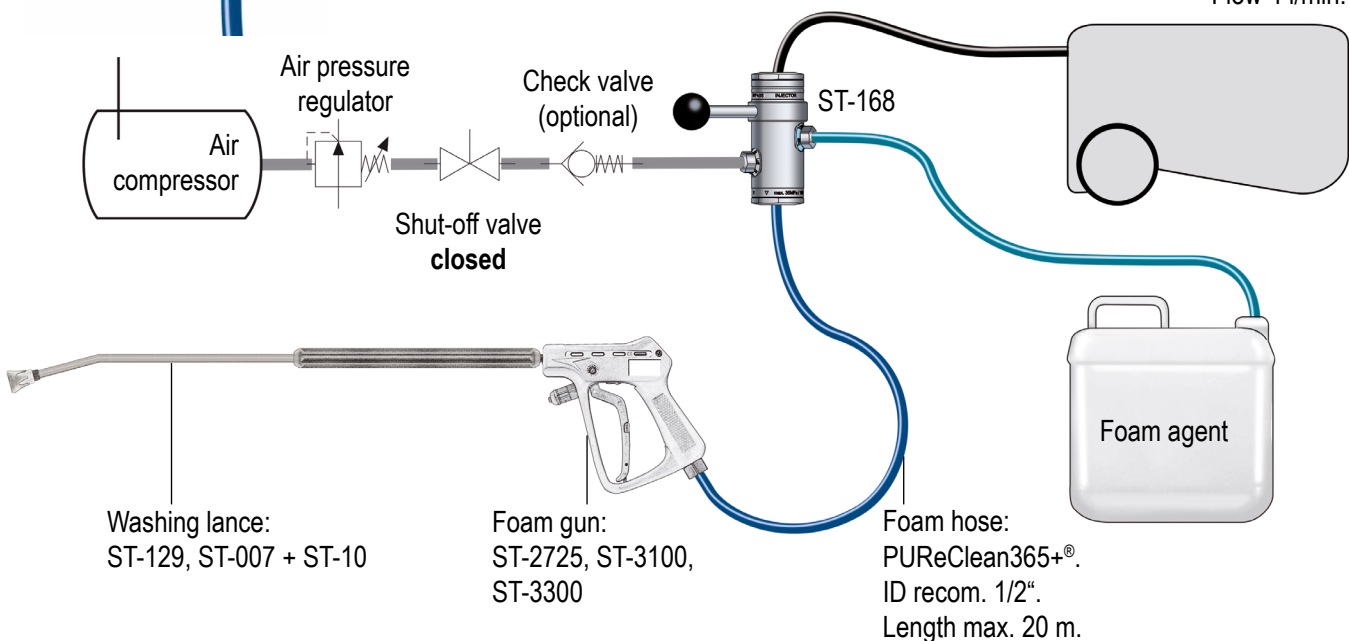

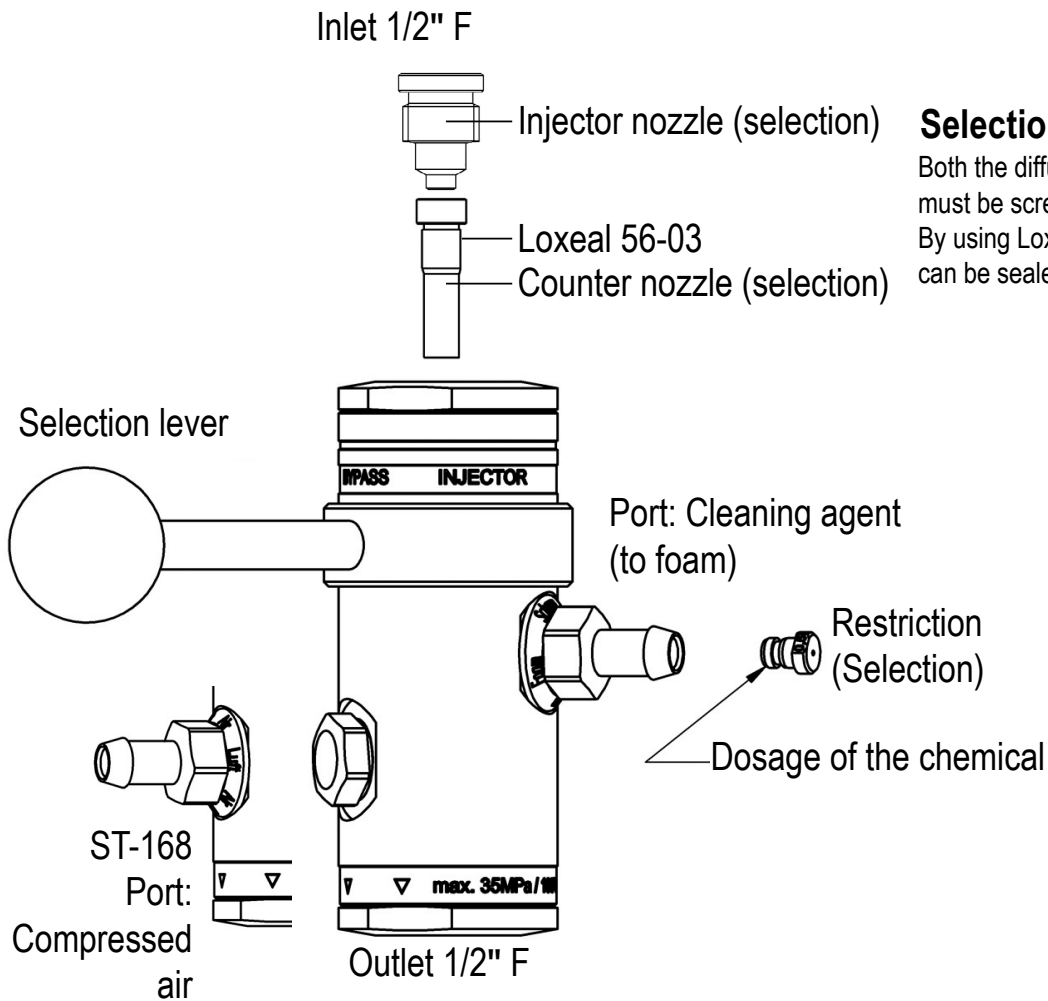

Selection of nozzles

Both the diffuser nozzle and the injector nozzle must be screwed in as far as it will go. By using Loxeal 56-03 the diffuser nozzle can be sealed up.

Injector nozzle	Counter nozzle
040 003 641 (ø 1,1 mm)	040 003 514 (ø 1,4mm)
040 003 642 (ø 1,2 mm)	
040 003 643 (ø 1,3 mm)	040 003 517 (ø 1,7 mm)
040 003 644 (ø 1,4 mm)	
040 003 645 (ø 1,5 mm)	
040 003 646 (ø 1,6 mm)	040 003 521 (ø 2,0 mm)
040 003 647 (ø 1,7 mm)	
040 003 648 (ø 1,8 mm)	
040 003 649 (ø 1,9 mm)	040 003 523 (ø 2,3 mm)
040 003 650 (ø 2,0 mm)	
040 003 651 (ø 2,1 mm)	
040 003 652 (ø 2,2 mm)	
040 003 653 (ø 2,3 mm)	040 003 528 (ø 2,8 mm)
040 003 654 (ø 2,4 mm)	
040 003 655 (ø 2,5 mm)	
040 003 656 (ø 2,6 mm)	
040 003 657 (ø 2,7 mm)	04 0003 532 (ø 3,2 mm)
040 003 658 (ø 2,8 mm)	

Tool for changing a counter nozzle:

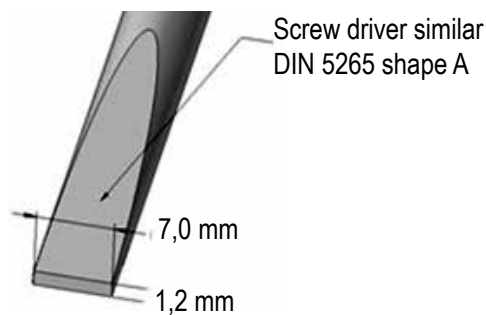

Description

Table reading example for *scale setting*

Flow volume: 15 l/min

Detergent or disinfectant concentration: 3 %

Calculated in accordance with the following formula:

$(3 \% * 15 \text{ l/min}) / 100 \% = 0,45 \text{ l/min}$ (dosage rate) => **graph setting 2** (read from diagram)

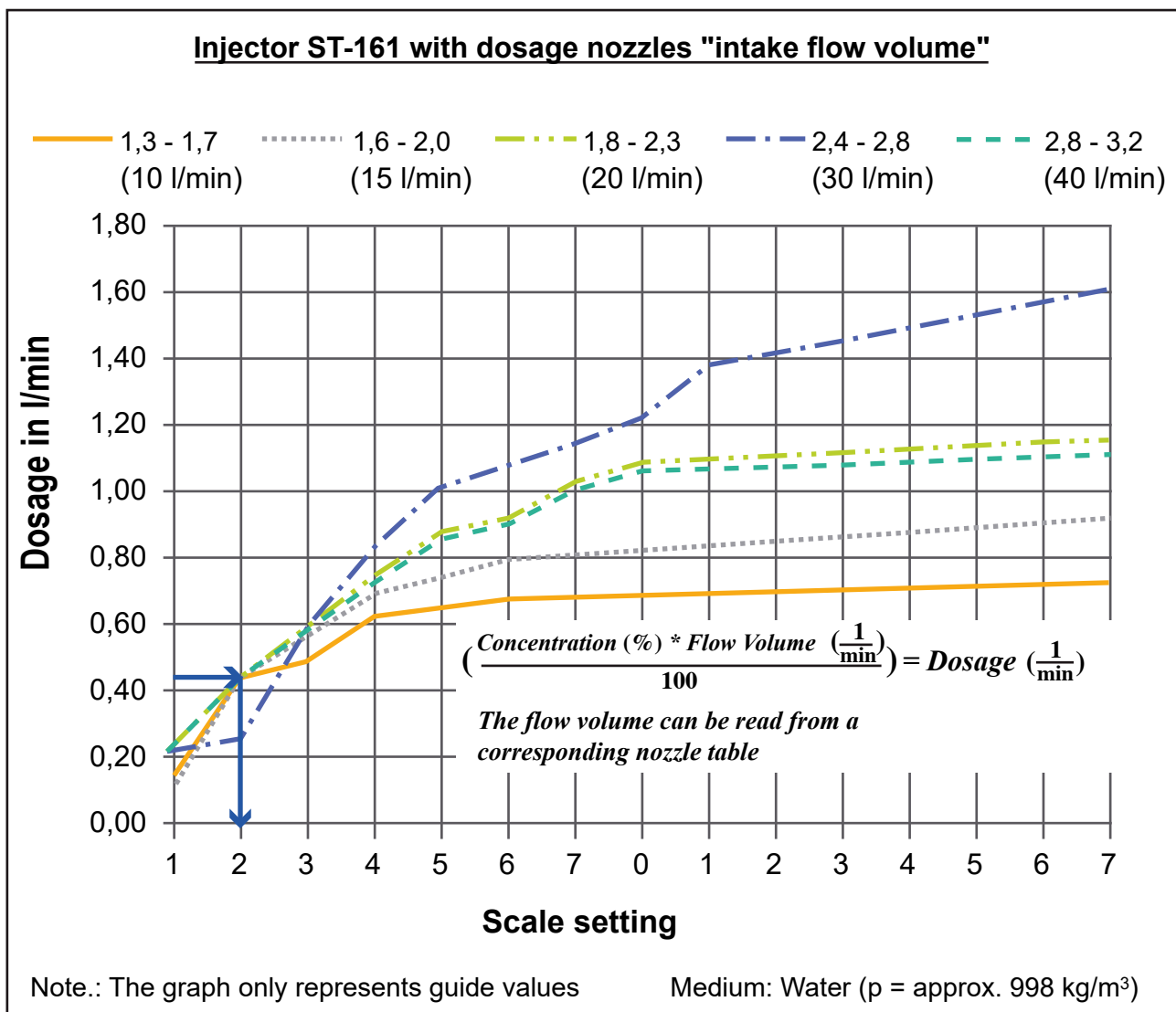

Description

Table reading example for *dosage nozzle bore*

Flow volume: 15 l/min

Detergent or disinfectant concentration: 5 %

Calculated in accordance with the following formula:

$(5 \% * 15 \text{ l/min}) / 100 \% = 0,75 \text{ l/min}$ (dosage rate) => **nozzle selection 1,2** (read from diagram)

